

ANDRITZ

Vertical line shaft pumps



Customized pump engineering

Solutions for customer needs

For over 100 years, ANDRITZ has been a byword for competence and innovation in building centrifugal pumps.

Extensive experience and great flexibility in accommodating our customers' needs have made ANDRITZ a preferred partner on a global scale. Beginning with R&D, continuing with design and manufacture, to after-sales-service, ANDRITZ combines the entire value added chain under one roof.

Fields of application

In water transport for . . .

- irrigation and drainage
- drinking and industrial water supplies

In power supply as . . .

- cooling water pumps for power stations
- flue gas desulphurization pumps

In seawater desalination as . . .

- seawater intake pumps

Materials know-how

ANDRITZ pumps transport many different media. The pumps must have various properties, depending on the medium concerned. That is why the choice of material and suitable finishing are the determining factors in functioning and stability of the pump.

Different materials are used depending on the service conditions and customer requirements: cast iron, cast steel, non-alloyed and low-alloy steel grades, stainless CrNi steel grades, Duplex and Superduplex steel grades.

Design variants

- Model pull-out or non pull-out
- Impeller radial, semi-axial or axial
- Impeller blades fixed, adjustable or variable during operation
- Flow rates up to 20 m³/sec
- Heads up to 80 m
- Different arrangement variants are used according to customer requirements

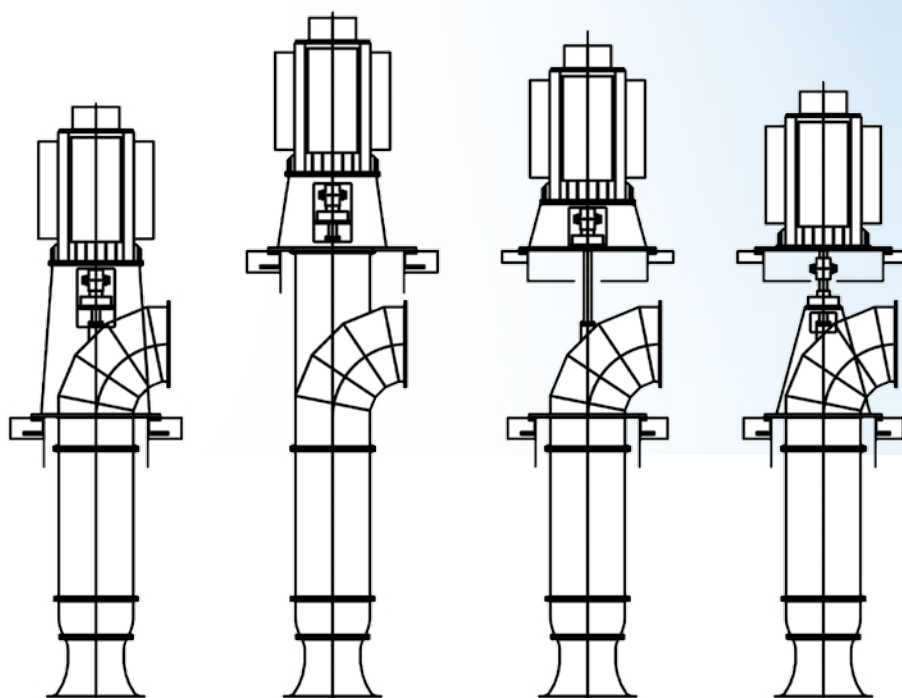

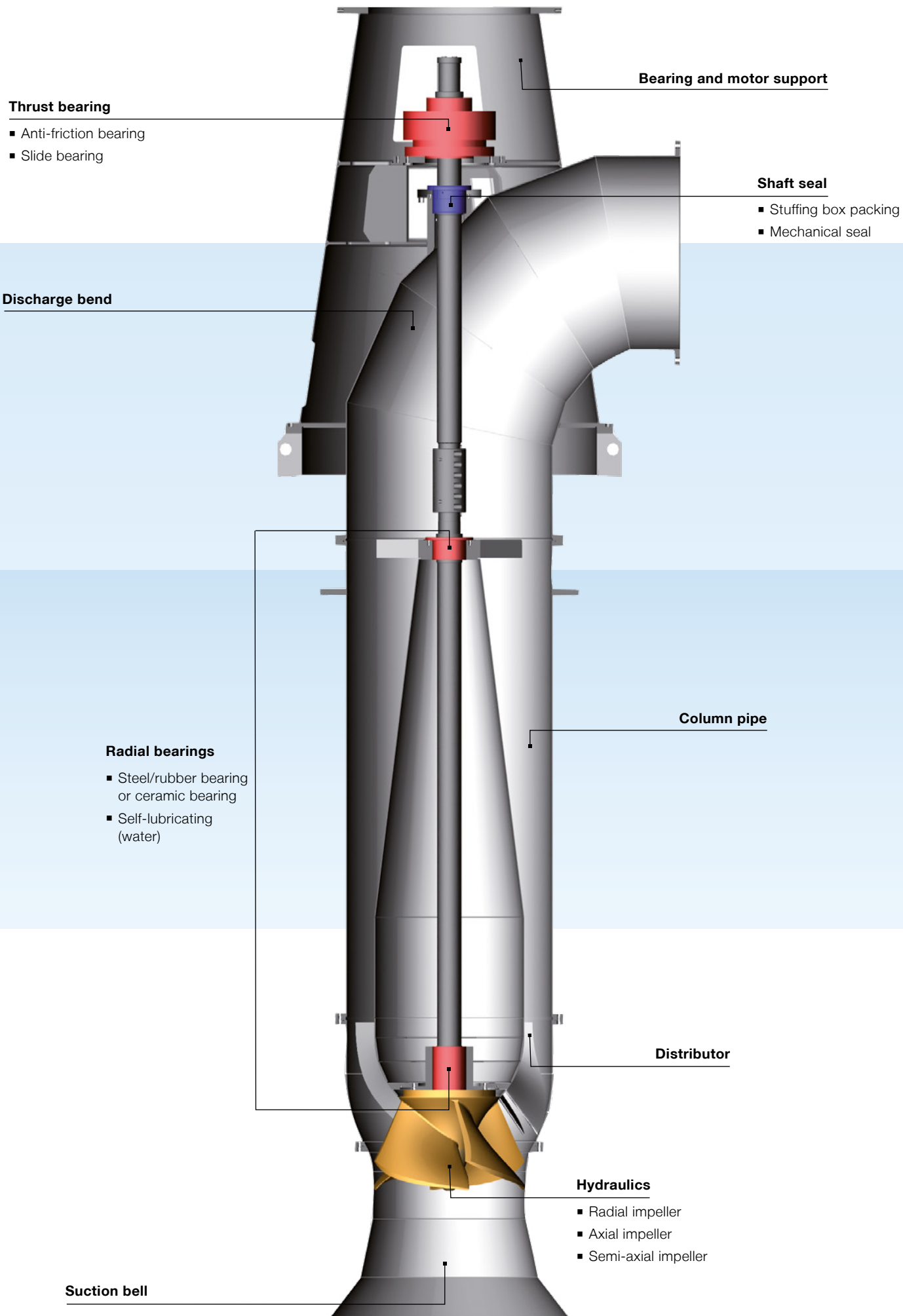

Flexible operating range

Various impeller shapes

ANDRITZ offers a complete program of impeller shapes for all combinations of delivery rates and heads, according to specific speeds. By varying the trailing edge, high-precision adjustments can be made to the desired duty points.

Hydraulic impeller blade adjustment

The hydraulic blade adjustment mechanism allows the impeller angle to be varied continuously during operation. Thus, the operator can react promptly to changes in flow rate and head. A servo-cylinder that can be fed with pressure oil from both sides is used to rotate the impeller blades via sliding blocks and adjustment crank handles.

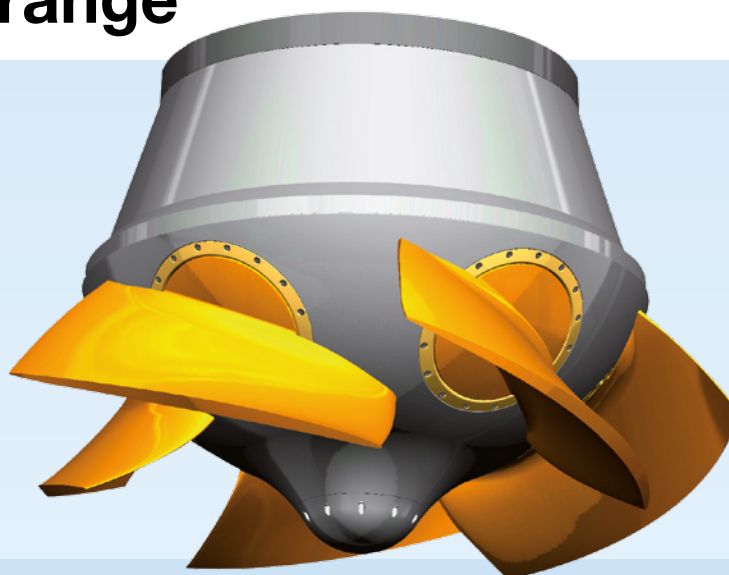

Thus, the pump can be set quickly and easily to the required flow rates and heads. In addition, the adjusting mechanism features long service life and low maintenance requirement.

Speed control

Flow rate and head can also be controlled by means of a continuously variable speed control unit for the drive, using a frequency converter. Here, ANDRITZ has put together the ideal concept for pump, drive motor and frequency converter to optimize efficiency.



Angle-adjustable blades

By using separately mounted, angle-adjustable impeller blades, it is possible to compensate any uncertainties in the system design. As a result, the efficiency can also be optimized or the duty point altered at a later stage. In this case, the angle of the impeller blade can still be adjusted manually to suit new conditions before installation and start-up.

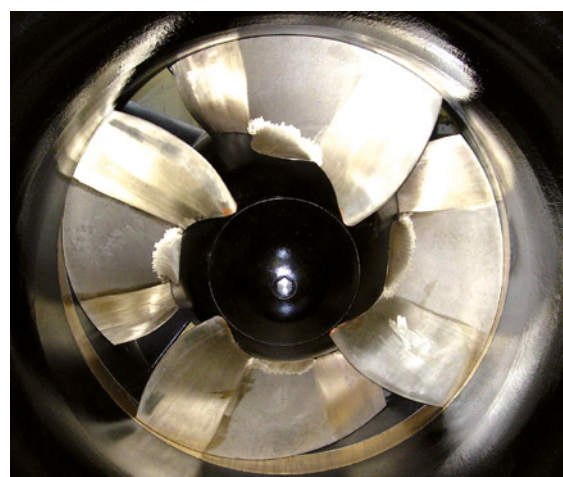

Competence to convince you

Custom-tailored solutions

ANDRITZ is a byword for customized pump solutions at the highest level. In the interests of our customers we set no limits on size and flow rate in the development and manufacture of customer-specific pumps.

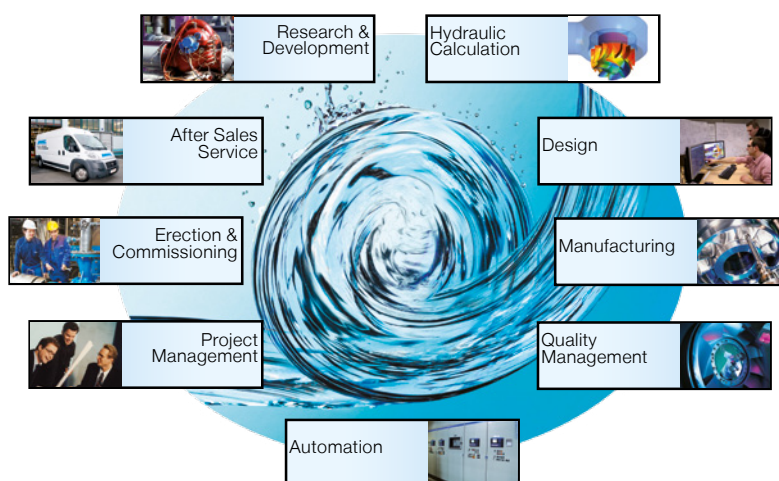

Experienced experts assist our customers with planning, development, installation, start-up and after-sales service. Engineering, design, material selection and manufacturing all run according to defined standards. The processes are transparent and can be adapted to individual needs.

R&D in fluid dynamics

Pumps with highest efficiencies and excellent cavitation properties are developed in our own laboratory for fluid dynamics, ASTRÖ, to meet the requirements of our customers.

Efficient Development Process

Our highly qualified and experienced engineers rapidly develop new pumps with the latest CFD tools, including model and inspection tests. Special peripheral conditions, such as the inlet and discharge arrangement of the pumps, can be investigated and optimized.



Close to our customers

ANDRITZ locations worldwide



ANDRITZ AG

Stattegger Strasse 18
8045 Graz, Austria
Phone: +43 (316) 6902 2873
Fax: +43 (316) 6902 406
martin.unterkreuter@andritz.com



www.andritz.com/pumps