

# **PUREVO – the pharma centrifuge**

The next generation in separation technology



ASK YOUR  
SEPARATION  
**SPECIALIST**

A glass of water is in the upper left corner, and a blister pack of white tablets is in the lower half of the image. A blue circle is overlaid on the right side, containing text.

“With more than 25 years  
of experience, ANDRITZ  
SEPARATION is the global  
specialist for pharmaceutical  
solid/liquid separation solutions.”

**MANAGEMENT  
ANDRITZ SEPARATION**

# Are you ready for a new chapter in your success story?

Innovative, customer-oriented thinking is perhaps one of the most significant characteristics of ANDRITZ SEPARATION. As a strong partner around the globe, we are dedicated to finding tomorrow's solutions today. And as part of the ANDRITZ GROUP, we can rely on an international network of highly qualified specialists and leverage worldwide synergies to provide you with sophisticated technologies, extensive know-how, and excellent services.

## **Solutions for any challenge**

ANDRITZ SEPARATION is the global specialist with the broadest technology portfolio in solid/liquid separation. Wherever you are, and regardless of the size of your company, we're there for you. With more than 150 years of experience in solid/liquid separation as well as reliable and timely service. And with innovations that boost capacity, maximize profitability, and help you ensure the success of your projects – from single machines to complete solutions.

## **Your trusted partner**

For many years, we have been cooperating with the main players in the pharmaceutical industry in order to improve the efficiency of their separation processes and the purity of their products. Meanwhile, we can look back on more than 25 years of experience with over 250 Krauss-Maffei pharma centrifuge installations worldwide – a track record that not only underscores our status as the global separation specialist but as a strong partner for the pharmaceutical industry as well.

## **Want to know what's in it for you?**

ANDRITZ SEPARATION provides you with the optimum equipment for your separation challenge: Based on our continuous R&D efforts aimed at developing state-of-the-art separation technologies, we make it our business to help you achieve your objectives in highly competitive markets.

So, if you want to know what's in it for you, just turn over to the next page and learn more about our innovative PUREVO pharma peeler centrifuge. It might just be the page where your success story really begins ...

# PUREVO – the pharma centrifuge

## Proven technology meets innovation

Are you exposed to tough market conditions? Looking for ways to ensure flexibility in your production and increase your product quality? How would you like to have an extremely high-performance solution at your disposal that can help you achieve these goals and even more? If so, it might be the right time to take a closer look at PUREVO – the pharma peeler centrifuge from ANDRITZ SEPARATION.

### Fits your toughest needs

Producing pharmaceuticals is very cost-intensive. Not only because it involves expensive raw materials and considerable R&D efforts, but also because the industry is subject to constantly changing legal requirements. With the PUREVO pharma centrifuge, ANDRITZ SEPARATION provides you with an innovative solution designed to minimize losses and maximize the purity of your products. Built from high-performance materials for hygienic processing, PUREVO meets the rising demand for high-quality pharmaceuticals with high reliability, low maintenance, and exceptional ease of operation.

### A history of utmost flexibility

PUREVO is the advancement of the Krauss-Maffei HZ Ph peeler centrifuge from ANDRITZ KMPT, a part of ANDRITZ SEPARATION.

In close cooperation with our customers, proven technologies have been combined with innovative design features leading to excellent separation capabilities. The PUREVO pharma centrifuge ensures maximum levels of product purity, yield, and flexibility. This advanced horizontal peeler centrifuge is not only ideally suited for the dewatering of products such as active pharmaceutical ingredients (APIs), antibiotics, pharmaceutical intermediate products, and active substances, etc., it can also be used for solid/liquid separation in the area of food processing. In both cases, the PUREVO pharma centrifuge meets rigorous hygiene requirements and ensures utmost application flexibility due to quick and easy product changes.

### Main applications

- Pharmaceuticals and fine chemicals (APIs, antibiotics, pharmaceutical intermediate products, etc.)
- Special fields (vitamins, liquid crystals, etc.)
- Food (sweeteners, amino/fatty acids, etc.)

### Processing parameters

- Filter area: 0.4-2.5 m<sup>2</sup>
- Solids content: From 3% by wt.
- Average particle size: 1-250 µm
- Wash efficiency: Excellent
- Solids recovery: Almost 100%

### Materials of construction

- Various grades of stainless steel
- Nickel-based alloys/titanium
- Special metals with or without lining



“The PUREVO pharma centrifuge combines proven technology with innovative features that enable our customers to meet their individual process needs.”

**JOSEF STANNER**  
PRODUCT MANAGER  
PEELER CENTRIFUGES  
ANDRITZ SEPARATION

RELIABLE  
PERFORMANCE

EASY  
MAINTENANCE

EXPERTISE IN  
AUTOMATION

HYGIENIC  
DESIGN



▲ PUREVO 1250 pharma peeler centrifuge

# Design advantages for your convenience

## Sophisticated features for high performance

Active pharmaceutical ingredients or intermediates are highly valuable and sensitive products. They have to comply with highest quality standards. To continuously guarantee the highest performance levels, the PUREVO pharma peeler centrifuge is equipped with specific features for the pharmaceutical industry.

### **Specific pharma design ensures high hygienic standards**

All surfaces are of high quality, and dead zones have been eliminated to allow for ideal cleanability. Following a hygienic drive concept, only pneumatic/electric drives are used in order to meet the highest standards in terms of process and product purity. The PUREVO pharma centrifuge is equipped with a fully inspectable process area (including the front shaft sealing).

### **No product contamination for high product purity**

The machine's special design keeps all lubricants and mechanical abrasion outside the process area and thus avoids product contamination. Moreover, seamless monofilament filter cloths prevent product bypass as well as abrasion.

### **Easy process monitoring for precise control and safety**

During operation, the basket, feed pipe, and peeler arm can be easily monitored by the operating staff through the inspection window. Analog and continuous detection and evaluation of the feed level are carried out by means of an analog feed control (FCA) system, which detects the liquid and solid level, or a contact-free measurement based on ultrasonics or radar.

### **Fast product change enables optimal centrifuge utilization**

Product changes can be performed quickly and the process parameters can be adapted easily to different product characteristics. The centrifuge features a fully automatic CIP program for guaranteed and validated cleaning within the shortest possible time. Thanks to our patented SmartFIX fastening system with endless tension strips, the filter cloth can be changed within a few minutes, thus reducing maintenance time and costs by around 50%.

### **Maximum yield thanks to patented discharge concept**

Thanks to its patented peeler and discharge geometry, fluidization, and pneumatic residual heel removal features, the PUREVO pharma centrifuge discharges products with virtually no losses. For its users, this means maximum yield, even with sticky products.

### **High g-forces for faster processing**

Higher g-forces compared to vertical centrifuges and inverting filter centrifuges enable faster product processing in the centrifuge. Furthermore, the resulting low residual moisture enables more efficient processing in the downstream equipment, e.g. dryers. This also leads to excellent washing quality and very high product purities.

### **Fast and easy installation, handling, and maintenance**

PUREVO pharma centrifuges are delivered fully assembled for time-saving installation. Working with the machine is also quick and easy, e.g. thanks to effortless opening/closing of the housing via automatic clamping ring. Furthermore, maintenance is simplified by the SmartFIX fastening system for fast exchanging of filter cloths and by the patented peeler knife and basket assembly with a reduced number of tools needed.

# PUREVOLUTION

▲ The PUREVO pharma centrifuge is a perfect combination of innovation and technological evolution that meets the highest hygienic and purity standards, a fact represented by the name "PUREVO", a compound of the words "PURE" and "EVOLUTION".

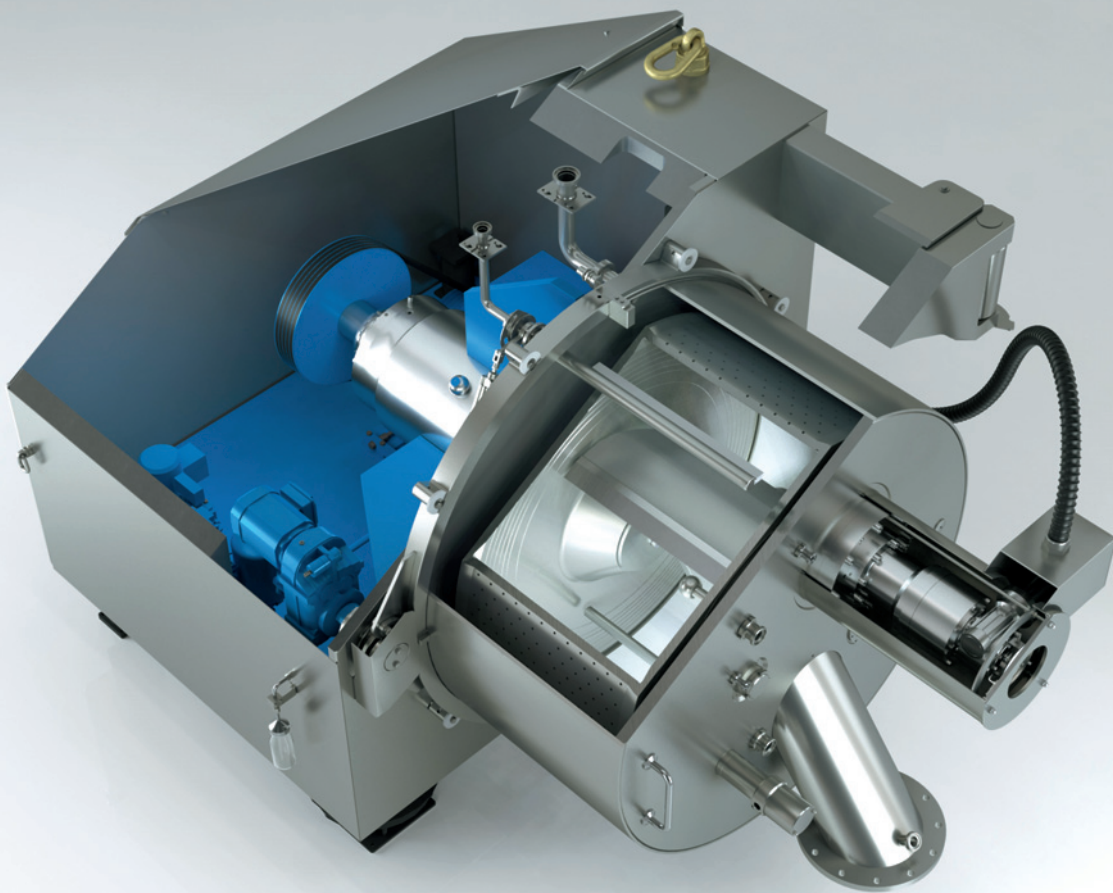

HYGIENIC  
DESIGN

## Hygienic design

### Engineered to meet the highest standards

More than in any other industry, the two fundamental requirements for successful production of pharmaceuticals are maximizing hygiene and minimizing impurities. By continuously optimizing the hygienic design of our machines, we are constantly setting new standards and developing smart solutions to meet the individual needs and high purity demands of our pharmaceuticals customers.

#### Extremely hygienic and easy-to-clean housing

One of the most striking features of the PUREVO pharma centrifuge is its hinged housing. By means of an electrically driven, extremely hygienic closing system, the housing can be opened easily, quickly and safely, and then swung to the side manually. This provides a full view of the entire process area with all the seals. The process area boasts generous radii and avoids dead zones and crevices to provide easy cleaning. All surfaces have a high-quality finish.



▲ Clean room installation

HYGIENIC  
DESIGN



▲ Process area: Smart features for efficient processing

**Your benefits**

- Compliance with highest purity demands
- Fast and automatic cleaning
- Less waste, no residues, higher product yield
- Easy access to all areas

**Clear hygienic separation of process and drive area**

All connections are fitted from the inside of the process housing and sealed with exposed O-rings. The process can be fully inspected through a sight glass. Dead zones are virtually avoided in order to reduce product deposits. CIP nozzles are arranged in such a way that all areas can be perfectly accessed with cleaning agent. The housing can be flooded, enabling highly efficient cleaning. If required, the housing can be of pressure vessel or vacuum design.

The process and drive area of the centrifuge are kept completely separate for easy installation in clean rooms. The machine operates with a fully pneumatic/electric drive concept. In order to allow operation with highly active substances and provide maximum purity, the product does not come into contact with any of the operators, nor with the environment.



**Peeling device with covered chute:** Reliable discharge as no liquids can fall into the chute

**Discharge chute:** A gradient of 35° ensures safe solids flow

**Cleaning in place (CIP):** Verified cleaning procedure for highest levels of hygiene

**Feed pipe with feed distributor:** Homogeneous product distribution with minimal imbalances

**Feed control:** Process monitoring by contact-free measurement

**Sight glass with lamp:** Visual process observation to optimize process parameters

**Wash pipe for cake washing:** Highest washing efficiency with a minimum of cleaning agents

### **Cleaning in place (CIP) – faster cleaning without disassembly**

In the pharmaceutical industry, it is imperative to avoid cross-contamination between different product batches – which is why each product change requires extremely thorough cleaning of the equipment. To ensure fully automatic cleaning, the PUREVO pharma centrifuge is equipped with a proven CIP program developed – together with operators – by ANDRITZ KMPT. In combination with several rinsing nozzles that enable flooding of the entire centrifuge housing, the program is a key factor in the verifiable cleaning effect demanded by today's producers of pharmaceuticals.

### **Pre-cleaning**

In a first step, the cleaning agent is fed in via the cleaning nozzles at reduced rotational speed. Here, most of the remaining solids are removed from the basket and the interior of the housing.

### **Main cleaning**

All discharge pipes from the centrifuge are closed. The centrifuge is filled up to the basket rim with cleaning agent. The speed and direction of rotation are now varied according to a defined program. The machine undergoes effective cleaning through this "washing machine effect". Even the solids discharge chute is completely flooded at the end of this step.

### **Final cleaning**

The machine is rinsed out again with water fed in through the cleaning nozzles in order to remove the final residues and surface dullness.

### **Riboflavin test**

Before production actually starts, the effectiveness of the CIP procedure can be verified in a riboflavin test.

# Reliable performance

## Efficient operation

The individual cycle times for feeding, washing, dry spinning, and peeling vary, depending on the filtration characteristics, from just a few minutes to several hours. The operating principle is adapted to the prevailing process conditions, which allows easy product change. Process parameters are listed in a recipe that is stored in the centrifuge's control system.



▲ Feeding process without risk of overflowing



▲ Cake washing for the highest product purity



▲ Dry spinning for a maximum dewatering effect

### Controlled feeding

During the feed process, the slurry is fed into the centrifuge basket via the feed distributor. The feed level is measured by a feed controller, continuously detecting the level mechanically or contact-free. The basket is filled to approx. 75-85% of the basket rim height. When the filter cake reaches the desired height, the feed process is complete.

### Efficient cake washing

When the liquid has submerged, one or more wash cycles may be carried out. For this purpose, a wash liquid is fed into the basket via the feed pipe or an optional washing pipe. The level of the wash liquid is controlled during the feed procedure by the feed controller. Especially in pharmaceutical synthesis steps, cake washing is an essential step in order to provide the specified product purity.

### Powerful dry spinning

At the end of the washing process, the centrifuge is gradually accelerated to full speed. The spinning process continues until the desired residual moisture content of the cake is achieved. This is usually the mechanical dewatering limit, which is well below the residual moisture attainable with vacuum or pressure filters. Cake formation and structure, as well as the filter cloth, are decisive in obtaining low residual moisture.



▲ Peeling without particle breakage

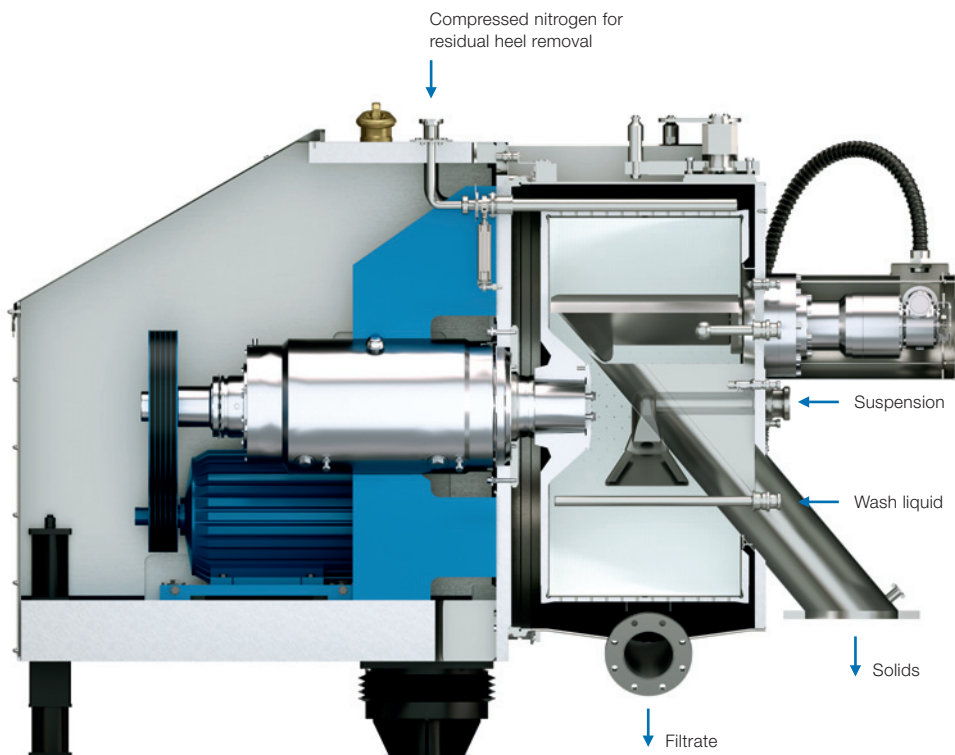

▲ Lateral view inside the PUREVO pharma peeler centrifuge

### Precise filter cake peeling

At the end of each centrifuge cycle, the filter cake is removed from the basket by a pivoting peeling device. To prevent particle breakage, peeling is conducted at reduced basket speed. The product is peeled off and discharged from the centrifuge through an inclined chute. To protect the filter medium, a thin layer of filter cake is retained in the basket. This layer, referred to as the residual heel, prevents fine particles from permeating into the filtrate in subsequent cycles.

### Patented peeler knife avoids product residues

During the washing and feed procedure, the patented peeler knife covers the discharge chute. In this way, splashes from the feed process cannot enter the chute, where they would subsequently cause sticking. Thus, it is also possible to discharge products that are sticky and difficult to handle.

### Intelligent nozzle arrangement prevents product deposits

Nitrogen is blown in through a patented nozzle arrangement integrated into the peeling device. The nitrogen buffer prevents any direct contact between solids and the surface.

### Minimized product loss due to pneumatic removal of residual heel

After several cycles or before product changes, the residual heel can be removed pneumatically. To increase the yield, it is necessary to discharge the residual heel with minimum product loss. A nozzle assembly on the outside of the basket is swung into the basket in order to remove the residual heel. Pressure pulses of compressed nitrogen are fed in through the nozzle assembly. The residual heel is detached from the filter cloth and discharged down the chute.



▲ Pneumatic removal of residual heel

### Your benefits

- Fast and easy change of product
- Low residual moisture
- Precise control of product purity
- Automatic feed control
- Peeling without particle breakage
- Residual heel removal with minimum product loss
- Prevention of product deposits
- Safe parameter storage

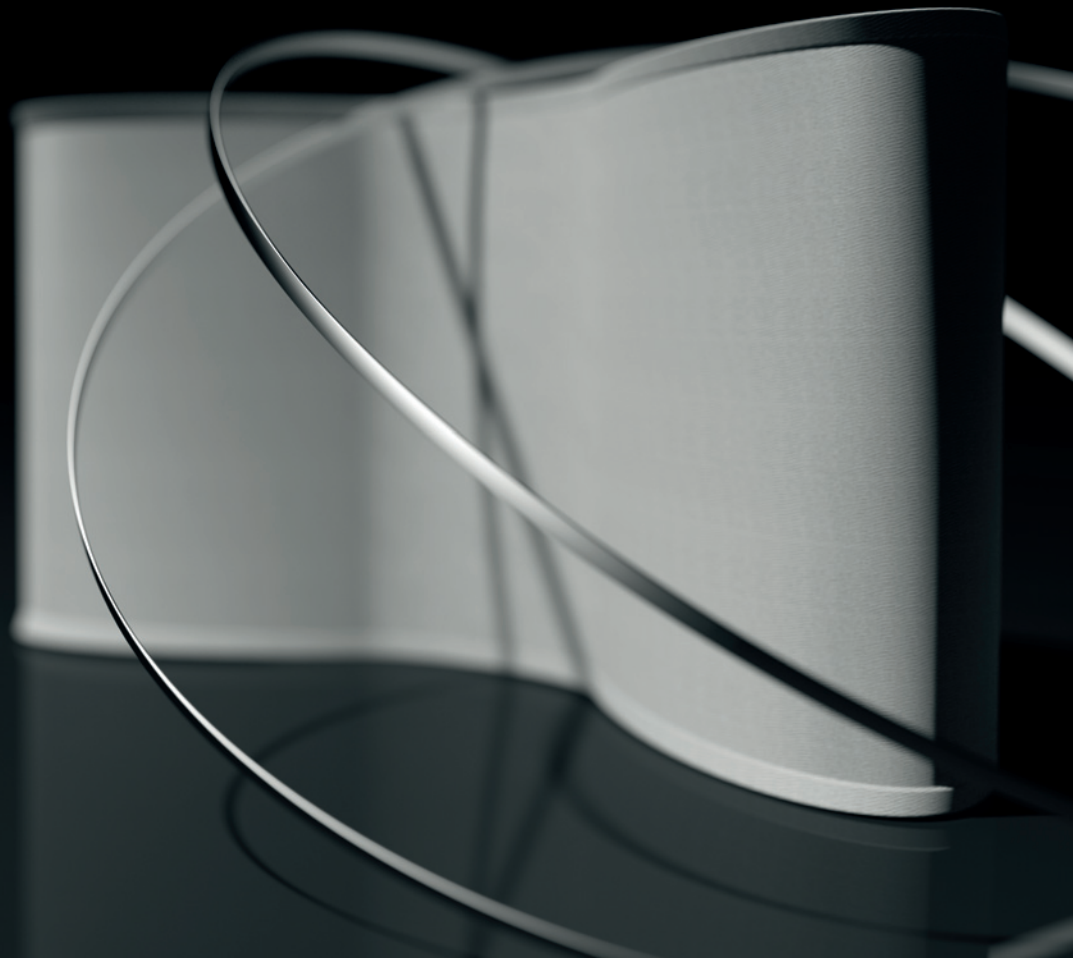

# Easy maintenance

## Little extras that make a big difference

Smart design, easy access to the drive and process area of the centrifuge, quick removal of essential parts that need maintenance at regular intervals, and minimized use of tools – all these are essential factors for easy maintenance. Thanks to a range of innovative, well-thought-out maintenance features, the PUREVO pharma peeler centrifuge offers its users maximum handling comfort. Moreover, significantly shorter downtimes for maintenance reasons immediately translate into longer uptimes, higher productivity, and optimized yield.

### Fast, reliable, and easy change of the filter cloth – with SmartFIX

The SmartFIX fastening system enables the operating personnel to change the filter cloth quickly and effortlessly. Thanks to specially designed, endless filter cloths and endless tension strips, the whole replacement process can be carried out in a matter of minutes.

The ANDRITZ SmartFIX for filter centrifuges is the latest and most innovative filter cloth fastening system on the market.

#### Your benefits

- Around 50% reduction in maintenance time and costs
- Improved production availability and performance
- Maximum safety for high-pressure applications
- Optimum cleanability and batch traceability specially for the pharmaceutical industry



▲ ANDRITZ SmartFIX for filter centrifuges

### Quick peeler knife exchange system

The maintenance-friendly peeler knife exchange system allows for significantly faster replacement of the peeler knife. The knife is held by a wedge-shaped geometry and secured with only two screws – this not only saves time, but also minimizes product residues in areas that are difficult to clean.

#### Your benefits

- Time-saving, economical maintenance
- Minimum amount of tools required
- Avoidance of product residues



▲ Smart peeler knife exchange system for fast and easy replacement

### Chute wiper for automatic cleaning

When handling sticky products, solids can build up in the discharge system and ultimately block the discharge chute. In a fully automatic peeling step, cake discharge is enhanced by using the patented chute wiper. This prevents blockages and eliminates product residues in the discharge chute.

#### Your benefits

- No more downtimes due to blockages
- Higher throughput, maximized yield
- Fully automatic process

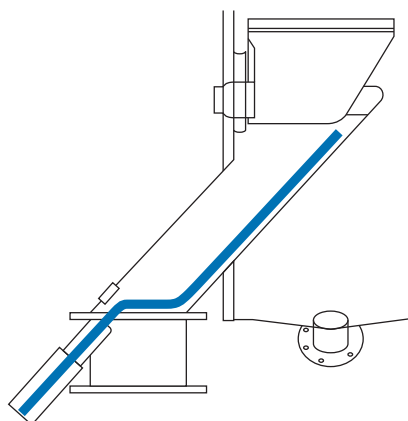

▲ Optional chute wiper for blockage removal

### Safe and easy basket assembly

Thanks to a practical clamping set, the basket can be connected to the shaft safely and easily with just a few tools. The basket can be assembled within a matter of minutes.

#### Your benefits

- Time-saving, economical maintenance
- Only a few tools required
- Clean and hygienic assembly/disassembly

### Hands-on training for professional centrifuge operators

In our popular and well-attended in-house seminars, operators of centrifuges receive extensive general training covering both mechanical and process aspects. We also offer customer-specific training that provides detailed information on individual process, machine or automation topics. Seminars can be attended either in a classroom in one of our training centers or directly at the customer site.

#### Your benefits

- Seminars held by experienced separation specialists
- Opportunity to ask specific questions and receive concrete answers
- Possible networking with industry colleagues

### Spare and wear parts always in stock

The secret to success lies in keeping your production lines running. In order to guarantee highest availability, especially of standard components, we have made considerable investments in our spare and wear parts inventories at our sites around the world.

# Feed control

## Reliable process observation

### Result-oriented control

In order to optimize processes and deal with frequent product changes, PUREVO pharma peeler centrifuges are equipped with appropriate measurement and control systems. This facilitates the continuous measurement of parameters such as the filling level in the basket, the filtration speed and the submersion point of the liquid in the filter cake.

The values measured are evaluated by the control electronics, and the process parameters, such as feed time, dry spinning time, wash time, etc., are optimized to suit. The control system is result-oriented.



▲ Installation of FCA (Feed Control Analog) in centrifuge

### Analog measurement

As a standard feature for challenging process conditions (varying solvents, foaming, etc.), PUREVO pharma centrifuges are fitted with the innovative feed control analog (FCA) system, a mechanical measuring system that observes the feed level continuously in the centrifuge basket and gives the operator detailed feedback on the feeding and washing processes. This enables result-oriented operation of the centrifuge, with optimized throughput, washing, and product quality.

#### Your benefits

- Reliable analog measurement even with varying process conditions
- Compact, sophisticated design to minimize splashing
- Reduced surface area to prevent product deposits forming
- Prevents overfilling of the basket to eliminate product losses

### Contact-free measurement

As an option, ANDRITZ KMPT recommends contact-free measuring systems based on ultrasonics or radar. An ultrasonic sensor emits a measuring signal in the direction of the charge in the basket. The ultrasonic signal reflected by the charge is picked up by a sensor and evaluated by the control electronics. If different solvents are used, a reference measure guarantees compensation of different sound velocities.

#### Your benefits

- Avoids splashing and caking thanks to contact-free measurement
- Analog and continuous level detection of the liquid and the cake height
- Analog value can be stored electronically
- No mechanical adjustments at machine, feed height is determined in process parameter recipe
- No wear on the sensor, thus no contamination of the product with metal abrasion



## Test our lab

# We're all about finding the optimum solutions for your processes

ANDRITZ SEPARATION operates fully equipped test centers in close vicinity to its customers, offering both lab-scale and pilot-scale equipment.

Our experienced separation specialists will advise you in order to determine suitable technologies from our wide portfolio that are most appropriate for your product. We also include the upstream and downstream process tasks in our considerations and evaluate single-step or multiple-step process solutions, typically trying to

reduce the number of subsequent unit operations. In a first set of lab-scale trials, these technologies will be compared in an unbiased and independent review. Then, a second set of larger-scale tests will determine in detail the process parameters needed to optimize the operating conditions in your process.



We will provide a complete report recommending the best solution for your solid/liquid separation process, including scale-up information for the production equipment. Process warranties can be provided, even for new products. In addition, we can assist you in running long-term trials at your site with equipment from our rental machine pool. What's your separation challenge?

[\*Ask your separation specialist\*](#)

# Expertise in automation

## Optimized solutions for your convenience

With more than 100 sites and over 2,000 employees worldwide, ANDRITZ AUTOMATION is an international competence center for plant design, plant control, and machine control systems. As a one-stop shop, we provide complete automation solutions for machines like the PUREVO pharma peeler centrifuge as well as for their integration into plant layouts. Our products and services have helped operations achieve record start-ups, increase capacity, improve efficiency, and save money.



▲ Design drives machine efficiency

### State-of-the-art automation

Our ANDRITZ addIQ control system makes sure that you invest your money in the highest standards. It is based on the latest PLC and HMI technologies, such as Siemens S7-1500 F or Allen-Bradley Compact/Control Logix S, and has an integrated fail-safe system. Using different bus systems (preferably PROFINET), the control system can be linked to the existing DCS. VPN remote routers allow remote service and remote assistance at the customer's request.



▲ Siemens SIMATIC, TIA Portal (image courtesy of Siemens AG)

### Intuitive operator design for HMI

Our specialists have bundled the latest research findings and fresh insights into a solution package for HMI design. An intuitive operator design ensures full-scale efficiency in operation – from an individual machine up to an entire plant. An overall usability concept takes different requirements of the operating staff into account and, at the same time, enables operators with different levels of experience to fulfill their tasks. Easy-to-read icons diminish barriers of intercultural diversity and minimize translation and training efforts. There is one common HMI design that can be applied for all machines from ANDRITZ SEPARATION.



EXPERTISE IN  
AUTOMATION

**Safety first**

Many safety requirements have to be considered, e.g. HAZOP, risk analysis, the European Machinery Directive, or ATEX. For CE conformity, the machine and the control system must be seen as one unit. As a one-stop shop, ANDRITZ SEPARATION can provide you with state-of-the-art safety solutions from a single source.

**Ready for industry 4.0 (IoT)**

Thanks to our control system, you are well-prepared for industry 4.0. The latest PLC hardware and software, Ethernet technology, and integrated smart sensors are the basics for industry 4.0. Optional modules – such as dashboards for predictive maintenance, power consumption monitoring, or analysis tools – are available and/or constantly being developed.

**Support for qualification and validation**

We have many years of experience in assisting our customers with qualification and validation tasks in compliance with the criteria of good manufacturing practice (GMP) and good automated manufacturing practice (GAMP).

**Smart access – smart services**

The ANDRITZ Remote Service Portal provides easy web access to your machine: Monitoring and full control is ensured by a web browser via smartphone, tablet, or PC. Smart supervision of the current equipment status, peripherals, and machine performance is ensured. Optionally, service requests can be generated via smartphone app.



▲ Simulator-based operator training

**Operator training and certification**

ANDRITZ SEPARATION offers special training courses for its automation systems. In order to achieve the best possible results, we use individually tailored training systems that apply order-specific software for machine and process simulations. An ANDRITZ certificate proves that its recipient has successfully completed the training and is qualified to work with the respective system.

**Your benefits**

- Highly efficient automatic production processes
- Compliance with safety requirements
- Compliance with GMP and GAMP
- Use of state-of-the-art automation software
- Easy web access and remote monitoring
- Tailored operator training and certification

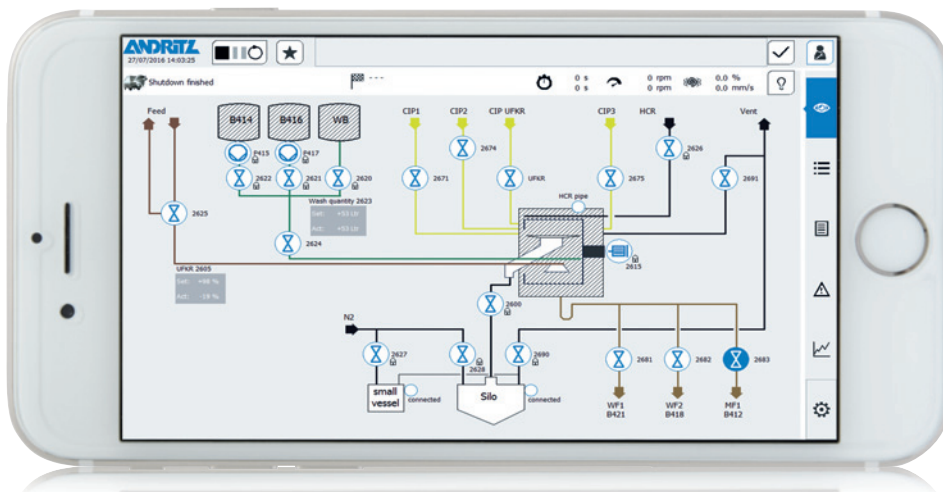

▲ Easy web access and intuitive operator guidance

# A world of service

Put our 150 years of OEM experience to work for you

With ANDRITZ SEPARATION, you gain access to one of the world's largest OEM manufacturers for solid/liquid separation systems, including such well-known brands and products as Krauss-Maffei centrifuges, dryers, and filters, Netzsch Filtration, 3Sys Technologies, Bird, KHD Humboldt Wedag, Rittershaus & Blecher, Guinard, Lenser, Escher Wyss, Royal GMF Gouda, Frautech, Vandenbroek, and Sprout Bauer. From initial consulting through to service agreements, plant optimization, automation, and training programs, we are always looking for ways to minimize downtime and increase predictability in operations while raising your overall production efficiency. Wherever you operate, our network of 550 service specialists and global service centers ensures that we are always there to support you for many life cycles to come. Let's sit down and see how we could take your operations to the next level.



## Local support

Responsive local service centers and field service technicians



## OEM spare parts

Wear and spare parts from OEMs or in OEM quality in local inventories



## Repairs & upgrades

Optimization of machine and process performance, repair work, retrofitting, and modernization



## Service agreements

Preventive maintenance, from contracts for spare parts, maintenance, inspections, and repairs to upgrades and operation



## Second-hand & rentals

Certified second-hand and rental machines



## Process optimization

Automation tools and process expertise to boost your profit



## Training

Operator training and tailored seminars for operating and maintenance personnel

# All data at a glance

## The PUREVO pharma centrifuge portfolio

To accommodate a broad range of application parameters and production capacities, the PUREVO pharma peeler centrifuge is available in different sizes.

### Dimensions and weights

Centrifuge model	L [mm]	W open [mm]	W closed [mm]	H [mm]	Weight [kg]
PUREVO 500	2,000	1,900	1,000	1,400	2,000
PUREVO 630	2,090	2,250	1,530	1,540	4,200
PUREVO 800	2,360	2,360	1,500	1,660	6,100
PUREVO 1000	2,680	2,680	1,710	1,910	9,100
PUREVO 1250	3,240	3,200	2,000	2,100	13,000

### Technical data

Centrifuge model	Basket diameter [mm]	Basket length [mm]	Basket volume [l]	Filter area [m <sup>2</sup> ]	Max. g-force*	Max. speed [rpm]*
PUREVO 500	500	250	20	0.4	2,030	2,700
PUREVO 630	630	315	44	0.6	2,030	2,400
PUREVO 800	800	400	88	1.0	1,600	1,900
PUREVO 1000	1,000	500	172	1.6	1,290	1,520
PUREVO 1250	1,250	630	340	2.5	1,000	1,200

\*) Basis: Density of saturated filter cake 1,250kg/m<sup>3</sup> at T = 50 °C  
All technical data are approximate and subject to change without notice.

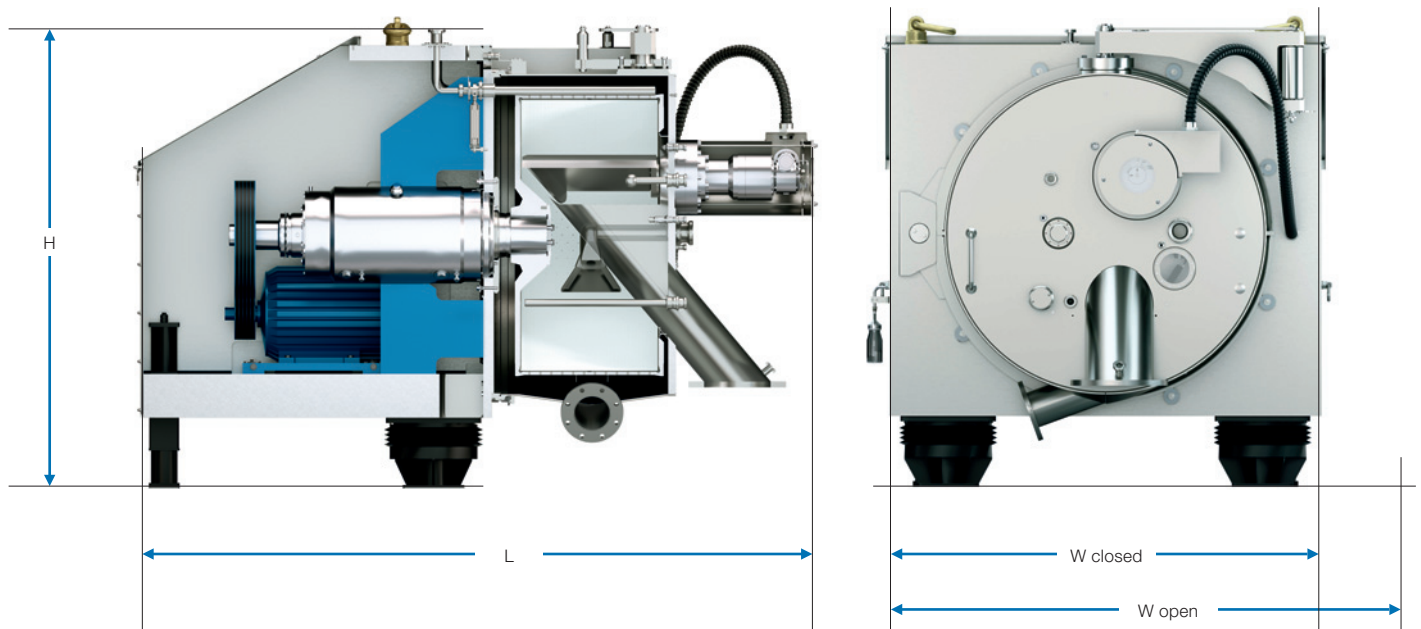

# What's your biggest separation challenge?



ANDRITZ SEPARATION is the world's leading separation specialist with the broadest technology portfolio and more than 2,000 specialists in 40 countries. For more than 150 years, we have been a driving force in the evolution of separation solutions and services for industries ranging from environment to food, chemicals, and mining & minerals.

As the OEM for many of the world's leading brands, we have the solutions and services to transform your business to meet tomorrow's changing demands – wherever you are and whatever your separation challenge.

***Ask your separation specialist***

#### AFRICA

##### **ANDRITZ Delkor (Pty) Ltd.**

Phone: +27 (11) 0127 300  
separation.za@andritz.com

#### ASIA

##### **ANDRITZ Singapore Pte. Ltd.**

Phone: +65 (6512) 1800  
separation.sg@andritz.com

#### AUSTRALIA

##### **ANDRITZ Pty. Ltd.**

Phone: +61 (3) 8773 4888  
separation.au@andritz.com

#### CHINA

##### **ANDRITZ (China) Ltd.**

Phone: +86 (757) 8258 6802  
separation.cn@andritz.com

#### SOUTH AMERICA

##### **ANDRITZ SEPARATION Ltda.**

Phone: +55 (47) 3387 9110  
separation.bra@andritz.com

#### NORTH AMERICA

##### **ANDRITZ SEPARATION Inc.**

Phone: +1 (817) 465 5611  
separation.us@andritz.com

#### PRODUCT HOME

##### **ANDRITZ KMPT GmbH**

Industriestrasse 1-3  
85256 Vierkirchen, Germany  
Phone: +49 (8139) 802990  
kmpt@andritz.com

**andritz.com/separation**