

Separators for the dairy industry



Gear drive separators

For decades ANDRITZ Frautech separators have been known for their high reliability and outstanding performance. This reputation is not without reason, smart design, the utmost care in the selection of the materials of construction and great attention to details mark any activity carried out at our workshop.

Stringent quality controls at any stage of the manufacturing process as well as during test runs ensure that only top quality separators are delivered to our customers. ANDRITZ Frautech gear drive separators represent the ideal solution for the most demanding quality-oriented dairies looking for separation efficiency, ease of operation and limited maintenance requirement.

Advantages

- Sturdy construction, made to ensure long-lasting operation
- Great separation efficiency
- Simple design making maintenance easy and inexpensive
- Balanced design of the mechanics
- Low decibel level
- Low vibration
- Reduced wear and tear of rotating parts

Features

- High-grade surface materials of construction
- High-grade finishing both for wetted and external parts to ensure great separation efficiency, proper sanitization and ease of cleaning
- Stainless steel execution
- Gear drive provided with hydraulic coupling for soft start and quick speed recovery after solids discharges
- VFD-drive available on some models
- Combined, oil-bath/splashing lubrication
- Electronically-controlled solids discharges
- Different controls available to match any requirements from basic to automated installations

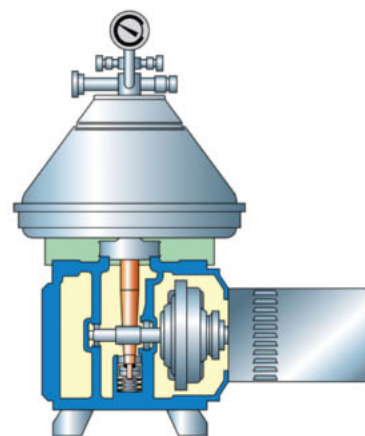

▲ Gear drive separator

Belt drive separators

Dairies all over the world are satisfactorily operating ANDRITZ Frautech belt drive separators every day. Since their introduction, in the middle of the 1980s, our belt drive separators have proven their reliability, efficiency and ease of use at small and large operations under any possible working conditions. Either for small dairies, processing just a few thousand liters of milk per day, or for large plants working on 24/7 basis, the ANDRITZ Frautech separators represent the right choice for any separation requirements in the dairy industry.

A wide range of capacities and designs, allow our customers to find the right model to suit their needs and enjoy the outstanding quality of a product that is the result of the strict application of our quality-oriented philosophy.

Advantages

- Great separation efficiency
- Ease of maintenance
- Extremely smart design
- Outstanding reliability
- Reduced operation costs (energy consumption and service)
- Reduced wear and tear of rotating parts
- Reduced sound pressure level
- Soft start and soft speed recovery after discharges, reducing mechanical stress, hence wear and tear
- Smooth running condition

Features

- VFD-driven, belt transmission on all models
- Top-quality materials of construction
- High-grade finishing both for wetted and external parts to ensure great separation efficiency, proper sanitization and ease of cleaning
- Integral stainless steel execution
- Innovative lubrication system ensuring optimum lubrication even at low speed
- Electronically-controlled solids discharges
- Different controls available to match any requirements from basic to highly automated installations
- Selected models available with 3A certification



▲ Belt drive separator

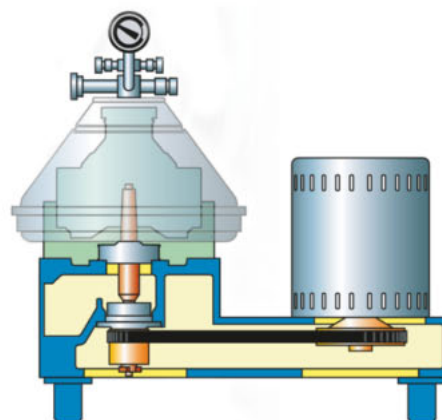

Milk clarifiers

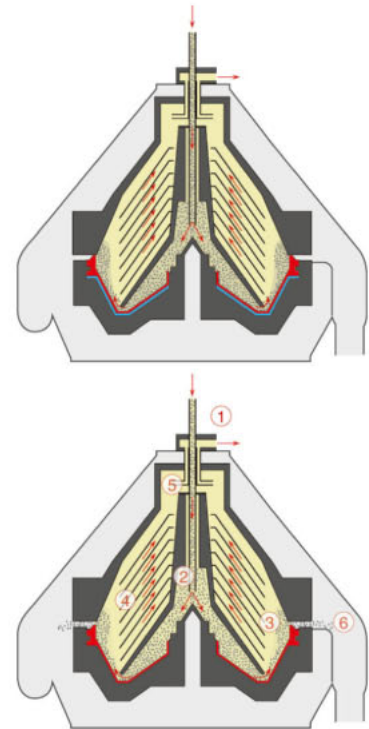

Milk clarification represents a very important step in milk processing when aiming at high-quality dairy products.

The purpose of milk clarification is the improvement of milk quality through the removal of solid impurities such as dirt, straw, hair and sand particles, somatic cells and bacteria.

The effective separation of solid impurities is strictly related to the viscosity of the milk: the lower the viscosity the higher the separation effect. Hence, for clarification purposes, warm milk is to be preferred to cold milk and a clarification temperature around 50 °C may be considered as the optimum temperature to achieve the maximum efficiency.

Nonetheless, especially in those areas where the raw milk quality is questionable, milk clarification is very often performed on cold milk, as soon as it is received at the dairy.

Specifically designed centrifugal separators, i.e. clarifiers, are used for milk clarification even though cream separators can be employed also; in this case the efficiency results are remarkably lower (up to 50-60% lower) as the separation of impurities is to be considered a secondary effect.

Self-cleaning milk clarifiers

- The milk is fed under pressure, through an enclosed pipe (1)
- It is then gently introduced into the bowl through the feeding pipe (2) and the distributor
- Solids subjected to the action of the centrifugal force, are forced towards the periphery of the bowl and accumulate in the solids space (3)
- The clarified milk rises through the disc stack (4), up to the centripetal pump (5) that discharges it out through an enclosed pipe
- The accumulated solids are automatically discharged at pre-set intervals (6)



Features & advantages

- Self-cleaning clarifiers, designed for automated C.I.P.
- Built-in, manual back pressure control for ease of installation and operation
- Stainless steel clad base frame
- High grade finish of any surfaces (wetted and non-wetted parts) for optimum sanitization
- Optimized motor control for soft start, quick speed recovery after discharge and low energy consumption
- Innovative lubrication to guarantee optimum working conditions and long life to bearings
- Time-controlled solids ejections allowing accurate discharges adjustment

- Stainless steel cabinet containing:
 - VFD (belt drive clarifiers)
 - Power section, including protections and start/stop commands for the feeding pump and the operating-water pump
 - LOGIX series control panel
- Cartridge filter and pressure reducer for the operating water
- Set of special tools
- Set of basic spare parts
- Lube oil (first charge + first change)

For options, see page 12.

Technical information

- Feeding pressure: 1 bar
- Discharge pressure: up to 4 bar
- Operating water: <100 l/h under normal working conditions
- Product connections: DIN 11851 - SMS - CLAMP

Standard scope of supply

- Stainless steel clad base frame
- Manual back pressure control for models up to size 200/201, automatic back pressure control for larger models
- Pressure gauge/probe at clarified milk discharge
- Solenoid valves for the operation of the hydraulic system of the bowl

| BELT DRIVE | | |
|------------|----------------|------------|
| Model | Capacity (l/h) | Motor (kW) |
| CA 11-P | 2,000 | 4 |
| CA 21-P | 3,500 | 4 |
| CA 31-P | 5,000 | 5.5 |
| CA 41-P | 7,500 | 7.5 |
| CA 61-P | 11,000 | 15 |
| CA 71-P | 15,000 | 15 |
| CA 91-P | 20,000 | 18.5 |
| CA 131-P | 25,000 | 22 |
| CA 151-P | 30,000 | 30 |
| CA 171-P | 35,000 | 37 |
| CA 201-P | 40,000 | 37 |
| CA 301-P | 50,000 | 45 |
| CA 351-P | 60,000 | 55 |
| CA 401-P | 70,000 | 55 |
| CA 501-P | 90,000 | 75 |

| GEAR DRIVE | | |
|------------|----------------|------------|
| Model | Capacity (l/h) | Motor (kW) |
| CA 40-P | 7,500 | 11 |
| CA 60-P | 11,000 | 15 |
| CA 70-P | 15,000 | 18.5 |
| CA 90-P | 20,000 | 18.5 |
| CA 130-P | 25,000 | 22 |
| CA 150-P | 30,000 | 30 |

Milk debacterizers

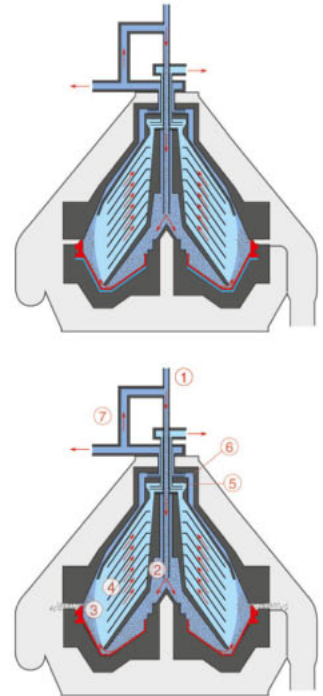

Bacteria removal from milk (and whey) allows significant quality improvements of final products. For instance in production processes, in which during the complete processing the milk temperature isn't raised above 50 °C – as in the production of raw milk cheese for example – a higher product quality can be reached when using a debacterizer.

Undesirable effects, often caused by bacteria are acid fermentation and cheese blowing. Furthermore the reason for a reduced shelf life of soft cheese and soft cheese based products may also be found in the presence of bacteria. Similarly, bacteria removal greatly contributes to longer shelf life of fresh milk and higher

quality of whey-derived products such as serum proteins.

ANDRITZ Frautech debacterizers represent the optimal solution for bacteria removal – employed with warm milk (ideally at 55-60 °C) for maximum separation efficiency, they guarantee a bacteria removal rate at the highest level.

Self-cleaning milk debacterizers

- The milk is fed under pressure, through an enclosed pipe (1)
- It is then gently introduced into the bowl through the feeding pipe (2) and the distributor
- The bacteria and other solids, subjected to the action of the centrifugal force, are forced towards the periphery of the bowl

and accumulate in the solids space (3) before being automatically discharged at pre-set intervals

- The clarified milk rises through the disc stack (4), up to the centripetal pump (5) that discharges it out through a closed piping
- The concentrate rises above the upper disc to reach the centripetal pump (6)
- The concentrate can be either discharged, or recirculated (7) into the bowl to further concentrate the bacteria for discharge



Features & advantages

- Self-cleaning debacterizers, designed for automated C.I.P.
- Built-in, manual back pressure control for ease of installation and operation
- Stainless steel clad base frame
- High grade finish of any surfaces (wetted and non-wetted parts) for optimum sanitization
- Optimized motor control for soft start, quick speed recovery after discharge and low energy consumption
- Innovative lubrication to guarantee optimum working conditions and long life to bearings
- Time-controlled solids ejections allowing accurate discharges adjustment

- Stainless steel cabinet containing:
 - VFD (for belt drive models)
 - Power section, including protections and start/stop commands for the feeding pump and the operating-water pump
 - LOGIX series control panel
- Cartridge filter and pressure reducer for the operating water
- Set of special tools
- Set of basic spare parts
- Lube oil (first charge + first change)

For options, see page 12.

Technical information

- Feeding pressure: 1 bar
- Discharge pressure, clarified milk: up to 5 bar
- Discharge pressure, concentrate: 2-2.5 bar
- Operating water consumption: <100 l/h under normal working conditions
- Product connections: DIN 11851 - SMS - CLAMP

Standard scope of supply

- Stainless steel clad base frame
- Manual back pressure control for models up to size 200/201, automatic back pressure control for larger models
- Pressure gauges/probes at clarified milk and concentrate discharge
- Solenoid valves for the operation of the hydraulic system of the bowl

| BELT DRIVE | | |
|------------|----------------|------------|
| Model | Capacity (l/h) | Motor (kW) |
| CA 41-D | 4,000 | 7.5 |
| CA 61-D | 6,000 | 11 |
| CA 71-D | 10,000 | 15 |
| CA 131-D | 15,000 | 22 |
| CA 171-D | 20,000 | 30 |
| CA 201-D | 25,000 | 37 |
| CA 301-D | 30,000 | 45 |
| CA 351-D | 35,000 | 45 |
| CA 401-D | 40,000 | 55 |
| CA 451-D | 45,000 | 55 |
| CA 501-D | 50,000 | 75 |

| GEAR DRIVE | | |
|------------|----------------|------------|
| Model | Capacity (l/h) | Motor (kW) |
| CA 40-D | 4,000 | 11 |
| CA 60-D | 6,000 | 15 |
| CA 70-D | 10,000 | 18.5 |
| CA 130-D | 5,000 | 22 |
| CA 170-D | 20,000 | 30 |
| CA 200-D | 25,000 | 37 |

Cream separators

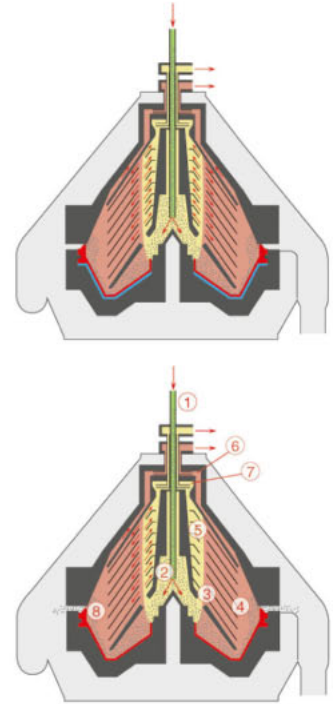

Cream separation either from milk or whey is a key process in the dairy industry. While in whey processing only full skimming is considered to recover the valuable fat, which remained in the whey after cheese production, in cream separation from milk either full or partial skimming can be applied. In the latter case it will be defined as milk fat standardization.

Gentle treatment of the milk, to avoid damages to fat globules, is an essential requisite that ANDRITZ Frautech separators can guarantee, thanks to the optimized design in feeding the separator. When full skimming is required, high skimming efficiency is a must and the ANDRITZ Frautech separators are designed to ensure, that under optimal feeding and process conditions, the residual fat in

skimmed milk is always at the lowest possible level, i.e. 0.05% or less. Milk fat standardization with ANDRITZ Frautech cream separators is made possible thanks to the built-in standardizing apparatus that allows the manual adjustment of the fat content in the skimmed milk.

Self-cleaning cream separators

- The whole milk is fed under pressure, through an enclosed pipe (1)
- It is then gently introduced into the bowl through the feeding pipe (2) and the distributor and starts rising through the rising channels (3)
- Due to the centrifugal force and its higher specific weight, the milk (4) is forced towards the periphery of the bowl while the cream (5) concentrates in the central part
- Both skimmed milk and cream rise along

their respective paths and reach the two centripetal pumps (6 and 7) that discharge them out of the separator

- Solids, that are also subject to the action of the centrifugal force, are forced towards the periphery of the bowl, they accumulate in the solids space (8) and are automatically discharged at pre-set intervals

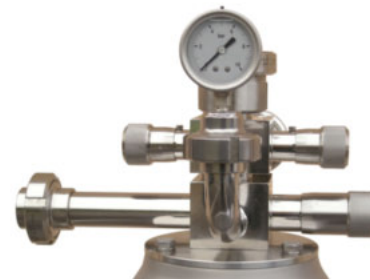

Features & advantages

- Self-cleaning cream separators, designed for automated C.I.P.
- Built-in, manual back pressure control for ease of installation and operation
- Built-in, manual milk fat standardization system
- Stainless steel clad base frame
- High grade finish of any surfaces (wetted and non-wetted parts) for optimum sanitization
- Optimized motor control for soft start, quick speed recovery after discharge and low energy consumption
- Innovative lubrication to guarantee optimum working conditions and long life to bearings
- Time-controlled solids ejections allowing accurate discharges adjustment

Standard scope of supply

- Stainless steel clad base frame
- Manual back pressure control for models up to size 200/201, automatic back pressure control for larger models
- Manual milk fat standardization unit for models up to size 200/201
- Pressure gauge/probe at skimmed milk discharge
- Pressure probe at cream discharge for models 251, 301 and 351
- Solenoid valves for the operation of the hydraulic system of the bowl

- Stainless steel cabinet containing:
 - VFD (belt drive cream separators)
 - Power section, including protections and start/stop commands for the feeding and the operating-water pump
 - LOGIX series control panel
- Cartridge filter and pressure reducer for the operating water
- Set of special tools
- Set of basic spare parts
- Lube oil (first charge + first change)

For options, see page 12.

Technical information

- Warm milk/whey skimming temperature: 45-55 °C
- Skimming efficiency: <0.05% (measured by Röse-Gottlieb method), under optimal feeding and process conditions
- Feeding pressure: 1 bar
- Discharge pressure, skimmed milk: up to 4 bar
- Discharge pressure, cream: up to 2.5 bar
- Operating water consumption: <100 l/h under normal working conditions
- Product connections: DIN 11851 - SMS - CLAMP

| BELT DRIVE | | |
|------------|----------------|------------|
| Model* | Capacity (l/h) | Motor (kW) |
| CA 11-T | 1,000 / 1,500 | 3 |
| CA 21-T | 2,000 / 3,000 | 4 |
| CA 41-T | 3,500 / 5,000 | 7.5 |
| CA 51-T | 5,000 / 7,500 | 11 |

| | | |
|----------|-----------------|------|
| CA 61-T | 6,000 / 9,000 | 15 |
| CA 71-T | 7,500 / 11,000 | 15 |
| CA 91-T | 10,000 / 15,000 | 18.5 |
| CA 131-T | 13,000 / 20,000 | 22 |
| CA 151-T | 15,000 / 22,500 | 22 |
| CA 171-T | 17,500 / 26,000 | 30 |
| CA 201-T | 20,000 / 30,000 | 30 |
| CA 251-S | 25,000 / - | 37 |
| CA 301-S | 30,000 / - | 45 |
| CA 351-S | 35,000 / - | 45 |
| CA 401-S | 40,000 / - | 55 |
| CA 451-S | 45,000 / - | 55 |
| CA 501-S | 50,000 / - | 75 |

| GEAR DRIVE | | |
|------------|-----------------|------------|
| Model* | Capacity (l/h) | Motor (kW) |
| CA 40-T | 3,500 / 5,000 | 11 |
| CA 60-T | 6,000 / 9,000 | 15 |
| CA 70-T | 7,500 / 11,000 | 18.5 |
| CA 90-T | 10,000 / 15,000 | 18.5 |
| CA 130-T | 13,000 / 20,000 | 22 |
| CA 150-T | 15,000 / 22,500 | 30 |
| CA 170-T | 17,500 / 26,000 | 30 |
| CA 200-T | 20,000 / 30,000 | 37 |

*T models:

Full skimming / standardization

Cream concentrators



When highly concentrated cream of up to 80% is required, special separators are used to concentrate the 35-40% cream that is usually obtained from other stages in dairy processing. These separators are required to ensure the high concentration of the cream, along with the lowest possible residual fat content in the discharged heavy phase. ANDRITZ Frautech cream concentrators are based on the well-tested design of the cream separators, specially modified to adapt to the working conditions that are typical of this application. Hence, gentle treatment of the product and high separation efficiency are peculiar features of this range of separators guaranteeing high quality and profitability.

Features & advantages

- Self-cleaning cream separators, designed for automated C.I.P.
- Built-in, manual back pressure control for ease of installation and operation
- Stainless steel clad base frame
- High grade finish of any surfaces, (wetted and non-wetted parts) for optimum sanitization

- Optimized motor control for soft start, quick speed recovery after discharge and low energy consumption
- Innovative lubrication to guarantee optimum working conditions and long life to bearings
- Time-controlled solids ejections allowing accurate discharges adjustment

Technical information

- Process temperature: ≥ 70 °C
- High separation efficiency: residual fat <0.5%
- Feeding pressure: 1 bar
- Skimmed milk discharge: under pressure, through centripetal pump
- Cream discharge: under pressure, through centripetal pump
- Operating water consumption: <100 l/h under normal working conditions
- Product connections: DIN 11851 - SMS - CLAMP

Standard scope of supply

- Stainless steel clad base frame
- Manual back pressure control
- Pressure gauge at skimmed milk discharge
- Pressure gauge at cream discharge
- Solenoid valves for the operation of the hydraulic system of the bowl
- Stainless steel cabinet containing:
 - VFD (belt drive cream separators)
 - Power section, including protections and start/stop commands for the feeding pump and the operating-water pump
 - LOGIX series control panel
- Cartridge filter and pressure reducer for the operating water
- Set of special tools
- Set of basic spare parts
- Lube oil (first charge + first change)

For options, see page 12.

| BELT DRIVE | | |
|------------|----------------|------------|
| Model* | Capacity (l/h) | Motor (kW) |
| CA 41-CP | 800 | 7.5 |
| CA 61-CP | 1,500 | 15 |
| CA 71-CP | 2,000 | 15 |
| CA 201-CP | 4,000 | 30 |

3A certified separators



ANDRITZ Frautech separators are available in 3-A compliant execution.

Features & advantages

- Self-cleaning cream separators, designed for automated C.I.P.
- Manual back pressure control for ease of installation and operation
- Stainless steel clad base frame
- High grade finish of any surfaces (wetted and non-wetted parts) for optimum sanitization: <0.8 Ra
- Optimized motor control for soft start, quick speed recovery after discharge and low energy consumption
- Innovative lubrication to guarantee optimum working conditions and long life to bearings
- Time-controlled solids ejections allowing accurate discharges adjustment

- Solenoid valves for the operation of the hydraulic system of the bowl
- Stainless steel cabinet containing:
 - VFD (belt drive cream separators)
 - Power section, including protections and start/stop commands for the feeding pump and the operating-water pump
 - LOGIX series control panel
- Cartridge filter and pressure reducer for the operating water
- Set of special tools
- Set of basic spare parts
- Lube oil (first charge + first change)

For options, see page 12.

Technical information

- Warm milk/whey skimming temperature: 45-55 °C
- Skimming efficiency: <0.05% (measured by Röse-Gottlieb method), under optimal feeding and process conditions
- Feeding pressure: 1 bar
- Discharge pressure, skimmed milk: up to 4 bar
- Discharge pressure, cream: up to 2.5 bar
- Operating water consumption: <100 l/h under normal working conditions
- Product connections: in compliance with 3A certification

Standard scope of supply

- Stainless steel clad base frame
- Manual back pressure control
- Pressure gauge at product discharge

| BELT DRIVE | | |
|------------|-----------------|------------|
| Model* | Capacity (l/h) | Motor (kW) |
| CA 71-P | 15,000 | 15 |
| CA 91-P | 20,000 | 18.5 |
| CA 131-P | 25,000 | 22 |
| CA 201-P | 40,000 | 37 |
| CA 301-P | 50,000 | 45 |
| CA 351-P | 60,000 | 55 |
| CA 71-T | 7,500 / 11,000 | 15 |
| CA 131-T | 13,000 / 20,000 | 22 |
| CA 201-T | 20,000 / 30,000 | 30 |
| CA 251-S | 25,000 | 37 |
| CA 301-S | 30,000 | 45 |
| CA 351-S | 35,000 | 45 |
| CA 401-S | 40,000 | 55 |
| CA 451-S | 45,000 | 55 |
| CA 501-S | 50,000 | 75 |

*T models:

Full skimming / standardization

Accessories and special designs



▲ Skid-mounted units



▲▲ Special sanitization system



▲ LOGIX-EVO PLC control unit

ANDRITZ Frautech provides tailor-made designs to combine the outstanding performances of our separators with extra features that make the customer's life easier.

Whether a special layout is needed or the integration of the separator with the peripheral equipment, ANDRITZ Frautech specialists will develop the best possible solution to meet customer's needs.

Quick installation, ease of operation, user-friendly controls are all features that will allow a fast payback and ANDRITZ Frautech knows how important this is in everyday's business.

Options

- Operating-water supply unit
- Valves and instruments for flow control
- Tailor-made sanitization systems
- Vibration monitoring
- Stainless steel skid
- Automatic back pressure adjustment
- Automatic cream fat standardization
- Different control options, from basic controls to PLC-based units
- VPN-based remote assistance

Dimensions and weights

| BELT DRIVE | | | | | |
|----------------|-----------------|-------|-------|------------|-------------|
| Model | Dimensions (mm) | | | D min (mm) | Weight (kg) |
| | A | B | C | | |
| CA 11/21/31 | 950 | 1,100 | 600 | 1,300 | 335 |
| CA 41/51 | 1,360 | 1,420 | 750 | 1,600 | 1,060 |
| CA 61/71/91 | 1,510 | 1,450 | 850 | 1,850 | 1,250 |
| CA 131/151 | 1,950 | 1,630 | 1,250 | 2,500 | 2,000 |
| CA 171 | 1,950 | 1,680 | 1,250 | 2,500 | 2,100 |
| CA 201/251 | 1,950 | 1,750 | 1,250 | 2,500 | 2,150 |
| CA 301/351 | 2,150 | 1,920 | 1,300 | 3,200 | 3,700 |
| CA 401/451/501 | 2,220 | 2,010 | 1,350 | 3,200 | 4,100 |

| GEAR DRIVE | | | | | |
|------------|-----------------|-------|-------|------------|-------------|
| Model | Dimensions (mm) | | | D min (mm) | Weight (kg) |
| | A | B | C | | |
| CA 40 | 1,350 | 1,350 | 810 | 1,700 | 900 |
| CA 60 | 1,600 | 1,500 | 860 | 1,800 | 1,250 |
| CA 70/90 | 1,700 | 1,550 | 860 | 1,850 | 1,400 |
| CA 130/150 | 1,910 | 1,680 | 1,060 | 2,300 | 2,000 |
| CA 170 | 1,910 | 1,730 | 1,060 | 2,300 | 2,100 |
| CA 200 | 1,910 | 1,800 | 1,060 | 2,300 | 2,150 |

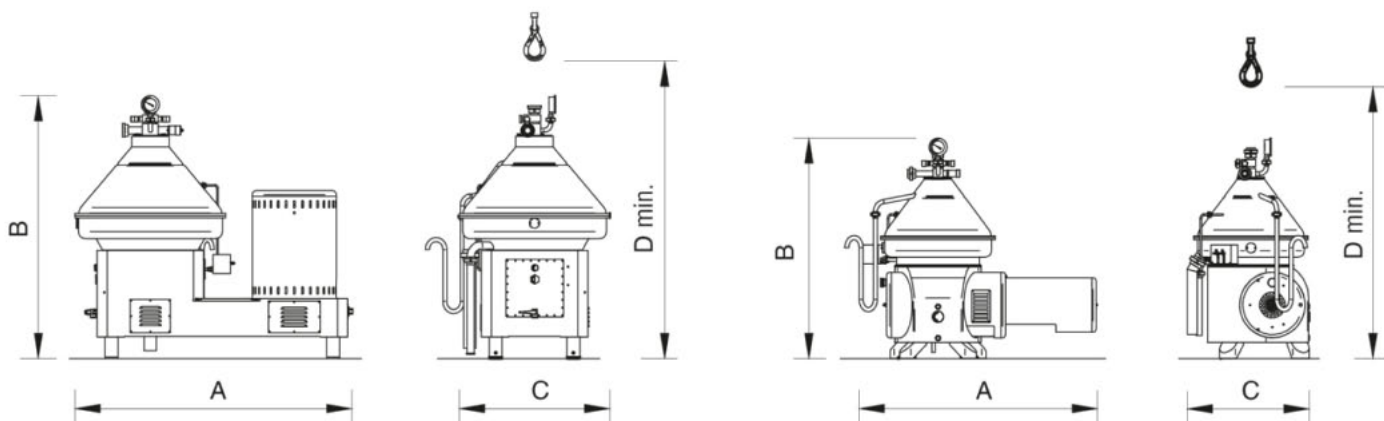

A world of service

Put our 150 years of OEM experience to work for you

With ANDRITZ SEPARATION, you gain access to one of the world's largest OEM manufacturers for solid/liquid separation systems, including such well-known names as Bird, KHD, Frautech, and more.

From initial consulting through to service agreements, plant optimization, automation, and training programs, we are always looking for ways to minimize downtime and increase predictability in operations while raising your overall production efficiency.

Wherever you operate, our network of 550 service specialists and global service centers ensures we'll always be there to support you for many life cycles to come. Let's sit down and see how we could take your operations to the next level.

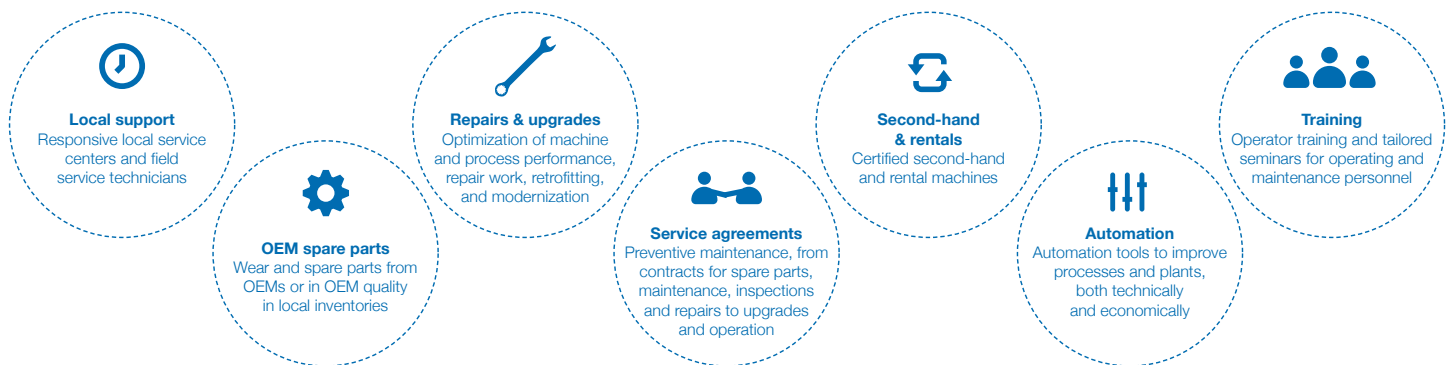
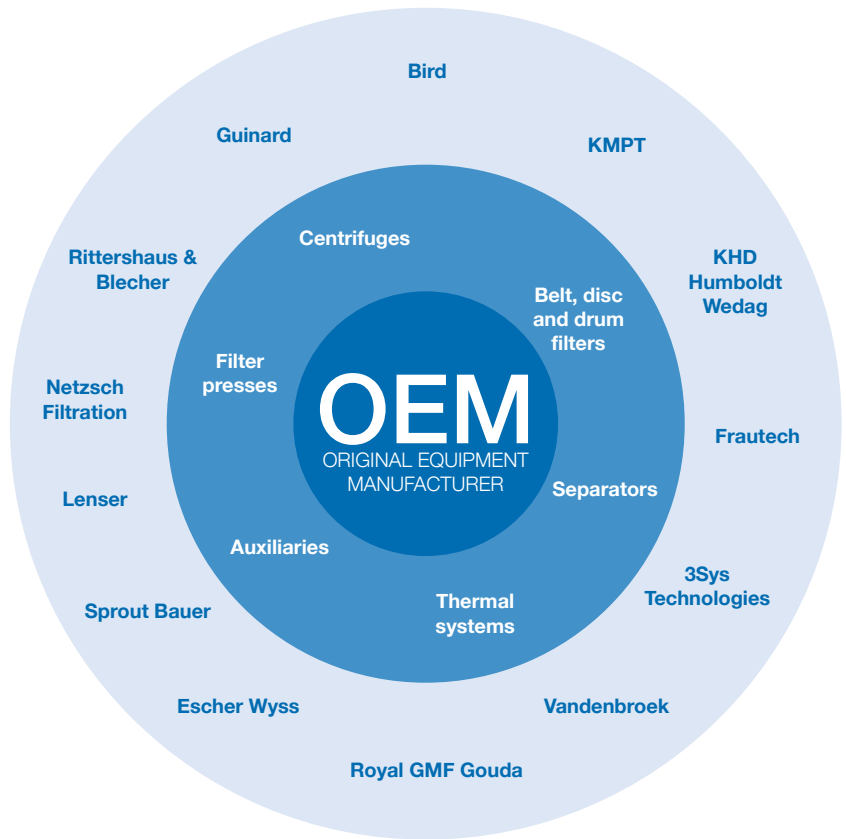

ANDRITZ SEPARATION



Since 2010 ANDRITZ Frautech has been part of ANDRITZ SEPARATION, a business area of the Austrian ANDRITZ GROUP. Based on technical expertise, engineering know-how, innovative thinking, as well as decades of experience, ANDRITZ SEPARATION offers reliable and efficient system solutions for mechanical and thermal solid/liquid separation.

With its comprehensive product range covering screens and screw presses, centrifuges, belt and filter presses, drying and thermal utilization systems, and all kinds of conveying equipment, ANDRITZ SEPARATION is a trusted partner worldwide.

For decades we have successfully served our international customers in various food industries with efficient separation equipment – here the dairy business is no exception as it is one of our key applications. Enabled by our extensive know how and experience in dairy production processes

we think outside the box, adapt processes where needed and support our customers along the value chain.

ANDRITZ SEPARATION's comprehensive product portfolio covers all main process stages within dairy production from clarification and skimming to concentration and standardization. Furthermore, additional equipment is also available for the production of by-products like butter, lactose, casein, and so on.

Separation technologies from ANDRITZ SEPARATION play a vital role in the efficient and profitable operation of hundreds of dairy plants all over the world – applied for instance in the processing of milk whey, cream and other dairy-related products such as baby food, milk-based drinks, ingredients for milk-based food and many more.

At ANDRITZ SEPARATION, we are providing our customers with decisive business advantages: from fundamental service consul-

tancy, wear and spare parts, to complete service contracts, all the way to repurchases of used machinery. With equipment known worldwide for being reliable, efficient, and maintenance-friendly, we strive for innovative and even more efficient solutions on a daily basis to best serve our customers' needs.



FOOD

ANDRITZ
Separation

ANDRITZ SEPARATION is a world leading supplier of plants and equipment for mechanical and thermal solid/liquid separation for various applications and industries. Decades of experience, a comprehensive product and service portfolio and an international sales network enable us to offer our customers efficient and reliable process solutions all over the world.



AFRICA

ANDRITZ Delkor (Pty) Ltd.

Phone: +27 (11) 012 7300
Fax: +27 (86) 636 2122
separation.za@andritz.com

AUSTRALIA

ANDRITZ Pty. Ltd.

Phone: +61 (3) 8773 4888
Fax: +61 (3) 8773 4899
separation.au@andritz.com

EUROPE

ANDRITZ Frautech S.r.l.

Phone: +39 (0445) 57 5695
Fax: +39 (445) 57 6723
separation.it@andritz.com

SOUTH AMERICA

ANDRITZ SEPARATION Ltda.

Phone: +55 (47) 3387 9100
Fax: +55 (47) 3387 9104
separation.bra@andritz.com

ASIA

ANDRITZ Singapore Pte. Ltd.

Phone: +65 (6512) 1800
Fax: +65 (6863) 4482
separation.sg@andritz.com

CHINA

ANDRITZ (China) Ltd.

Phone: +86 (757) 8258 6802
Fax: +86 (757) 8258 6828
separation.cn@andritz.com

NORTH AMERICA

ANDRITZ SEPARATION Inc.

Phone: +1 (817) 465 5611
Fax: +1 (817) 468 3961
separation.us@andritz.com

www.andritz.com