

IDEAS

VMG engine



The challenge: To design and control multi-component vapor liquid equilibrium systems



The solution: Simulate. Predict. And profit.

The IDEAS VMG engine combines the simulation strengths of IDEAS with the validated thermodynamic data provided by Virtual Materials Group (VMG) to support industries that require vapor liquid equilibrium (VLE) capability.

Accurate and reliable thermodynamics properties are essential for accurate and reliable process simulation and design of process equipment. VMG has invested many years of development and research into creating VMGThermo, which ANDRITZ AUTOMATION has integrated as an integral part of the IDEAS simulation platform. The result of this work is an engine capable of thermophysical and flash calculations. It has the versatility to run virtually any processing application. Its programming interface gives it the flexibility to be embedded in IDEAS.

The engine provides a complete set of physical and thermodynamic properties for pure components and mixtures over a wide range of pressures, temperatures, compositions, and phases, including a comprehensive database

of nearly 5,500 pure components, with more than 100 physical properties per component.

Multiphase flash system

VMGThermo's multiphase flash system has a robust material balance and phase stability algorithm. It calculates the number of phases in a process, as well as the composition, amount, and physical properties of the materials in each phase at thermodynamic equilibrium. Beyond process simulation, VMGThermo is continuously validated, giving it the capability to model a wide variety of systems.

EOS++

A subset of VMGThermo, EOS++ includes a number of equation-of-state models. For example, the model for hydrocarbon processing includes more than 250 interaction parameters for a wide range of process conditions.

ACTIVITY++

This is a carefully crafted set of models designed to provide thermodynamic properties for systems for the chemical, fine chemical, petrochemical, and pharmaceutical industries. The vapor phase may be modeled using several different equations of state,

such as Ideal Gas, Redlich-Kwong, Soave-Redlich-Kwong, Peng-Robinson, and Virial. Important non-condensable industrial gases, such as nitrogen, oxygen, hydrogen, and carbon dioxide, are included and automatically handled using Henry's Law, modified for handling of multi-component mixtures.

Comprehensive estimation

Missing pure component physical properties are automatically estimated using a recommended set of models. Missing interaction parameters for activity coefficient models are automatically estimated using UNIFAC. All estimated interaction parameters are documented and can be inspected by the user.

Summary of thermodynamic models

Some of the popular thermodynamic models (both equation-of-state and activity coefficient models) are described below.

Peng-Robinson

This model has a rich, built-in binary interaction coefficients database and ability to estimate interaction parameters. It includes special handling of water.

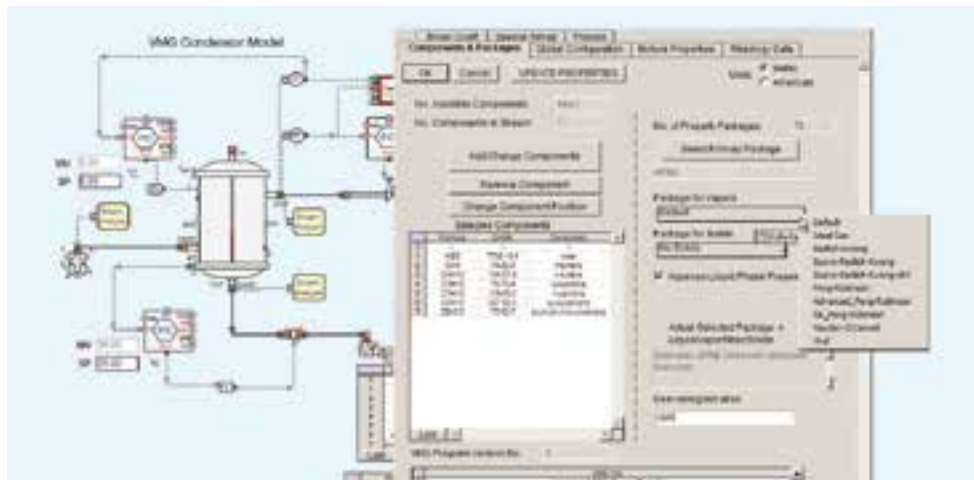

▲ Screen shot of the IDEAS VMG engine

Benefits

- Database with over 1,700 components allows user to perform multiple equilibrium and flash operations
- Library of dynamic models helps predict multiphase equilibrium

Advanced Peng-Robinson

Together with Peng-Robinson, this package provides volume translation correction for phase densities. Special handling for water, hydrogen, and helium is included, as well as polar compounds normally found in natural gas and refinery applications.

Ge Peng-Robinson

This model provides a modification of the Peng-Robinson equation-of-state designed to model accurately the vapor pressure of pure components together with a Gibbs excess mixing rule. It is ideal for modeling entire chemical processes involving polar substances with low and high pressure regions.

UNIQUAC/Ideal

The UNIQUAC activity coefficient model can be used with ideal gas law to model the vapor phase behavior.

UNIQUAC/Ideal/HC

The UNIQUAC activity coefficient model can be used with ideal gas law to model vapor phase behavior. The package includes special enthalpy, entropy, and heat capacity methods for hydrocarbons.

Wilson/Ideal/HC

Use the Wilson activity coefficient model with ideal gas law to model the vapor phase behavior. It includes special enthalpy, entropy, and heat capacity methods for hydrocarbons.

NRTL/Ideal/HC

The NRTL activity coefficient model can be used with ideal gas law to model the vapor phase behavior. It includes special enthalpy, entropy, and heat capacity methods for hydrocarbons.

SimpleSolid

This abstract package for inert solids can be used in an aggregate package to add solid supports to an existing package.

TKWilson/Ideal/HC

The Tsuboka-Katayama (TK) modification of Wilson activity coefficient model can be used with ideal gas law to model the vapor phase behavior. It includes special enthalpy, entropy, and heat capacity methods for hydrocarbons.

IdealLiquid/Ideal/HC

Ideal liquid behavior is assumed with all condensable activity coefficients set to unity.

SRK

This model is combined with a rich, built-in binary interaction coefficients database and interaction parameter estimation. It also includes special handling of water.

APISRK

The SRK method is combined with API-recommended built-in binary interaction coefficients database and interaction parameter estimation. It also includes special handling of water and hydrogen.

Yaws Physical and Yaws Thermal

These are abstract packages for empirical models for the calculation of physical and transport properties, and for thermal properties, respectively.

Hayden-O'Connell: This abstract package models systems with vapor phase association, such as carboxylic acid systems. This package provides vapor phase properties only.

Automation solutions

Release your full potential



ANDRITZ Inc.

Atlanta, GA, USA

Phone: +1 (404) 370 1350

Australia: Melbourne | Austria: Vienna | Brazil: Belo Horizonte, Curitiba | Canada: Nanaimo, Prince George, Richmond, Terrace | Chile: Santiago | Finland: Kotka, Tampere, Varkaus | India: Bangalore | USA: Bellingham, Montoursville

www.andritz.com
automation-sales@andritz.com